

LUFFING JIB TOWER CRANE

RTL 325 A-20

HR23/HP20_{I/II FALLS}

TECHNICAL DATA SHEET

RTL 325 A



MORITSCH
CRANES SINCE 1962





MORITSCH

C R A N E S S I N C E 1 9 6 2

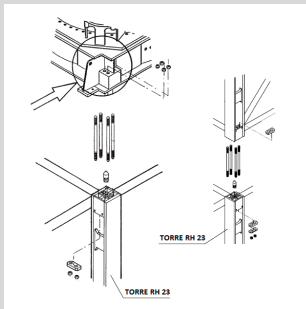

TOWER TYPE HR 23

The well known H beam mast sections with vertical bolts connection will allow greater free standing heights. Available in three versions: base reinforced (HR 23-30), heavy duty (HR 23-26) and std duty type (HR 23-22).

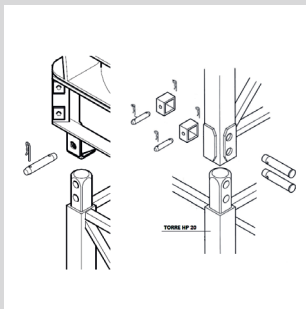

TOWER TYPE HP 20

The famous boxed beams -twin pins connections. Safety and performances trough pins.

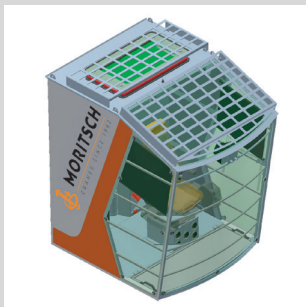

CABIN

New design CAB , wider, longer, with improved visibility. Grammer seat and gessman joy-stick for driver cofort and ABB controls for maximum safety. USB door, air con, easy cleaning of windows, 10" or 7" screen included.

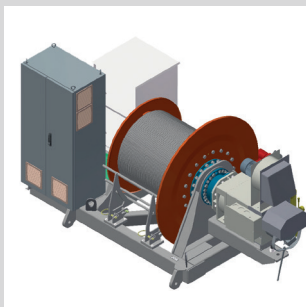

WINCHES

New generation of high power winches, from 110 kw. New braking system, new reduction gear to grant highest performances ever seen on a luffer.

RTL 325 A-20

HR23/HP20 I / II FALLS

CE EN 14439: 2009
FEM 1.001 - A3

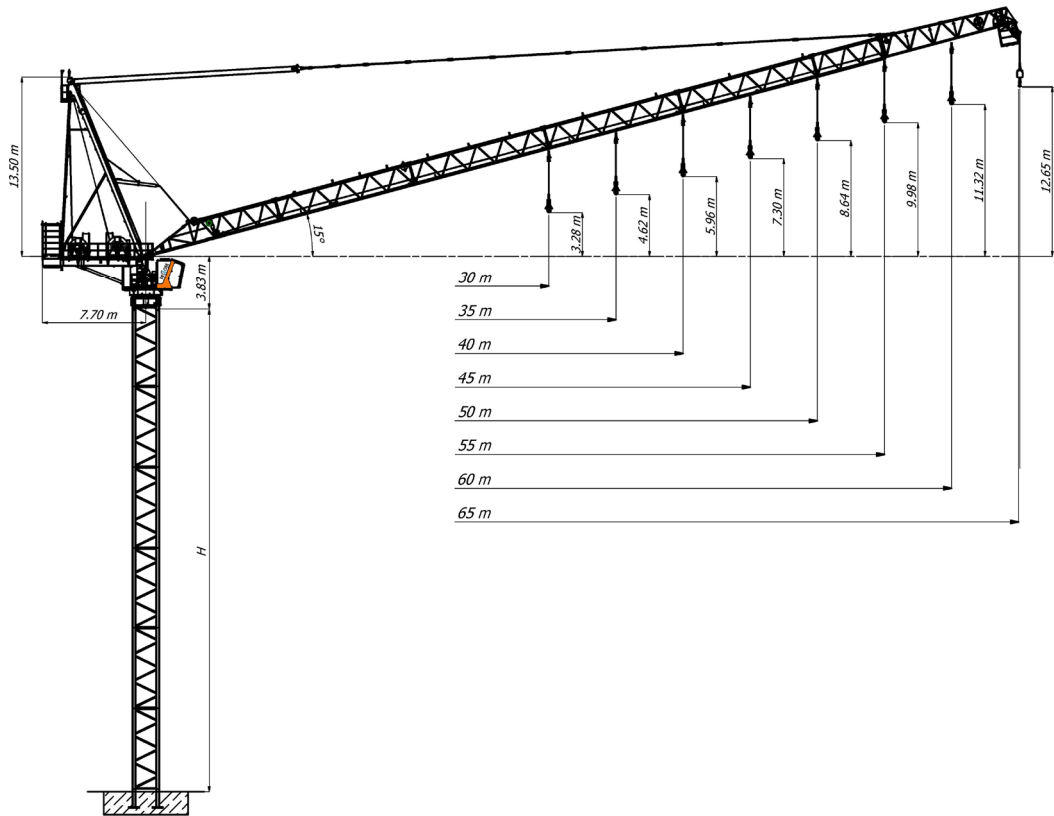

RTL 325 A - 20

(t)	m	15	20	25	30	35	40	45	50	55	60	65	
12	23,7	12,00	12,00	11,24	8,90	7,23	5,98	5,00	4,22	3,58	3,05	2,60	64,30 m
12	29,8	12,00	12,00	12,00	11,90	9,61	7,90	6,57	5,50	4,63	3,90		
15	23,9	15,00	15,00	14,14	11,10	8,93	7,30	6,03	5,02	4,19	3,50		59,30 m
12	31,1	12,00	12,00	12,00	12,00	10,20	8,41	7,02	5,91	5,00			
18	21,7	18,00	18,00	15,04	11,85	9,57	7,86	6,53	5,47	4,60			54,30 m
12	32,3	12,00	12,00	12,00	12,00	10,76	8,90	7,46	6,30				
20	21,0	20,00	20,00	16,10	12,73	10,33	8,53	7,12	6,00				49,30 m
12	33,3	12,00	12,00	12,00	12,00	11,20	9,29	7,80					
20	21,7	20,00	20,00	16,78	13,30	10,81	8,95	7,50					44,30 m
12	33,5	12,00	12,00	12,00	12,00	11,33	9,40						
20	21,9	20,00	20,00	17,02	13,50	10,99	9,10						39,30 m
12	33,3	12,00	12,00	12,00	12,00	11,20							
20	22,2	20,00	20,00	17,18	13,52	10,90							34,30 m
12	30,0	12,00	12,00	12,00	12,00								
20	22,4	20,00	20,00	17,24	13,30								29,30 m

RTL 325 A - 20

(lb)	ft	49	66	82	98	115	131	148	164	180	197	213	
26448	77,8	26448	26448	24773	19616	15932	13169	11020	9301	7894	6722	5730	210,90 ft
26448	97,8	26448	26448	26448	26228	21190	17412	14473	12122	10199	8596		
33060	78,3	33060	33060	31165	24464	19679	16089	13297	11064	9237	7714		194,50 ft
26448	102,0	26448	26448	26448	26448	22481	18541	15477	13026	11020			
39672	71,0	39672	39672	33148	26117	21095	17329	14399	12056	10138			178,10 ft
26448	105,9	26448	26448	26448	26448	23709	19616	16432	13885				
44080	68,7	44080	44080	35484	28064	22764	18789	15697	13224				161,70 ft
26448	109,1	26448	26448	26448	26448	24685	20470	17191					
44080	71,0	44080	44080	36983	29313	23835	19726	16530					145,30 ft
26448	110,0	26448	26448	26448	26448	24968	20718						
44080	71,9	44080	44080	37512	29754	24213	20056						128,90 ft
26448	109,3	26448	26448	26448	26448	24685							
44080	72,7	44080	44080	37865	29791	24024							112,50 ft
26448	98,4	26448	26448	26448	26448								
44080	73,4	44080	44080	37997	29313								96,10 ft



HR23

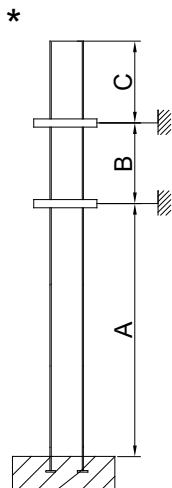
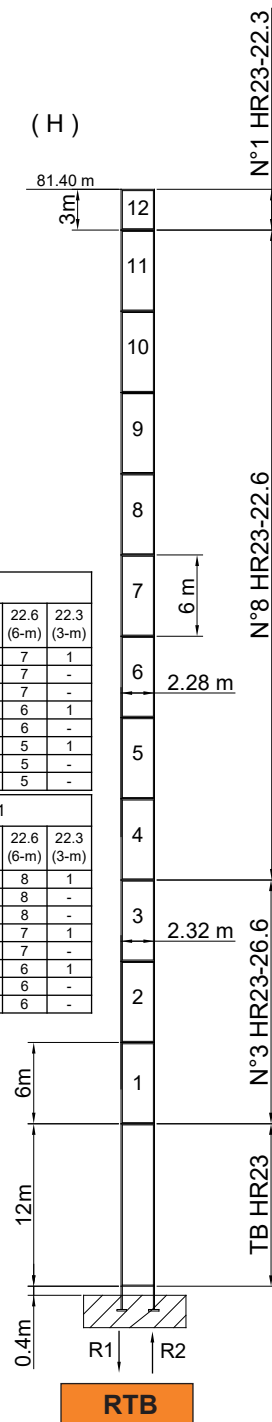
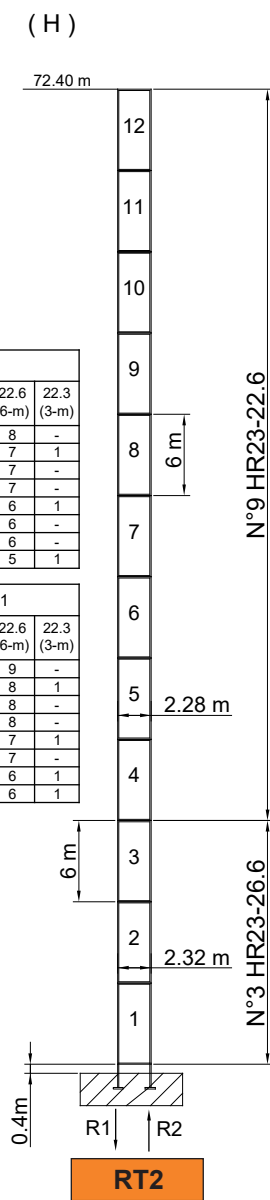
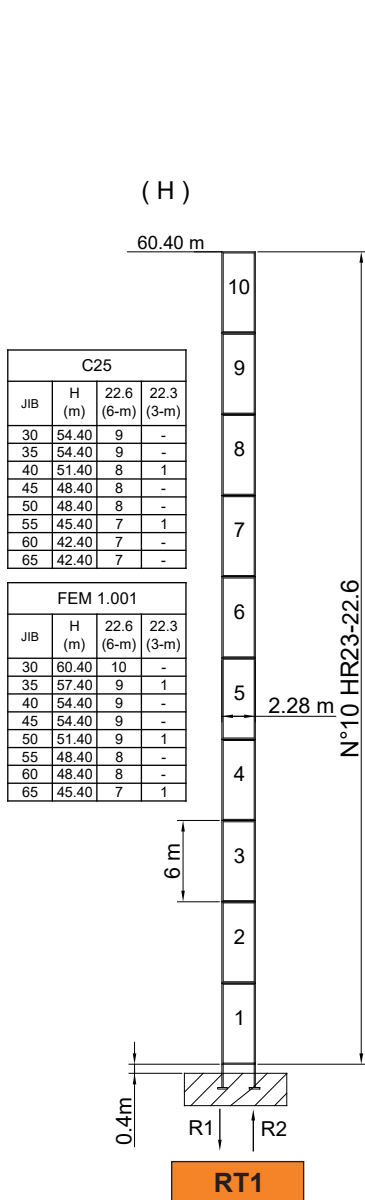

EXTERNAL CLIMBING

* Please ask tech. Dept.

(C25) FEM 1.004 out of service wind conditions

Different height and tower combinations are available - please consult us

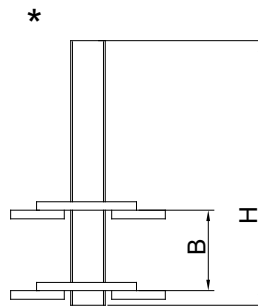

INTERNAL CLIMBING



RTL 325 A-20 HR23/HP20

HP20

C25 - FEM 1.001			
JIB	H (m)	TB/11.5 (11.5-m)	PRL/3.75 (3.75-m)
30	53.15	1	11
35	49.40	1	10
40	49.40	1	10
45	45.65	1	9
50	45.65	1	9
55	41.90	1	8
60	41.90	1	8
65	38.15	1	7

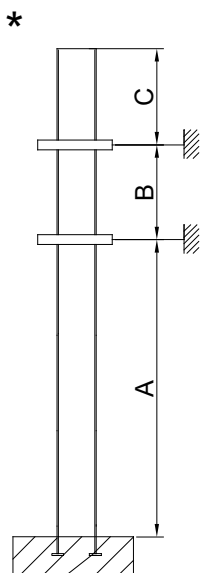
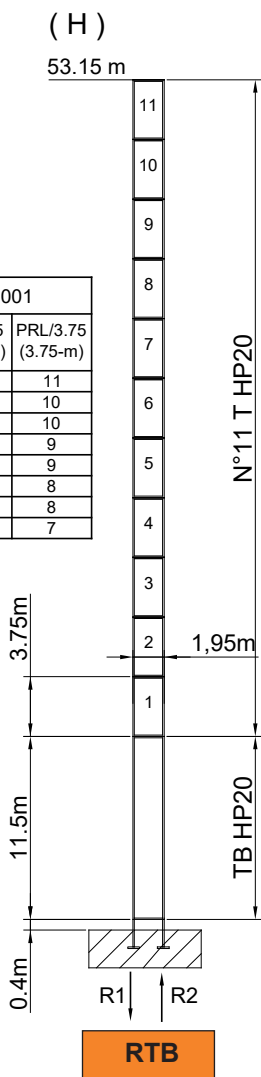

EXTERNAL CLIMBING

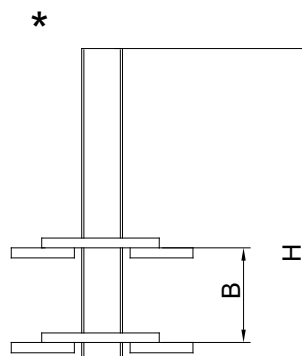

INTERNAL CLIMBING

* Please ask tech. Dept.

(C25) FEM 1.004 out of service wind conditions

Different height and tower combinations are available - please consult us

110 HVF 200

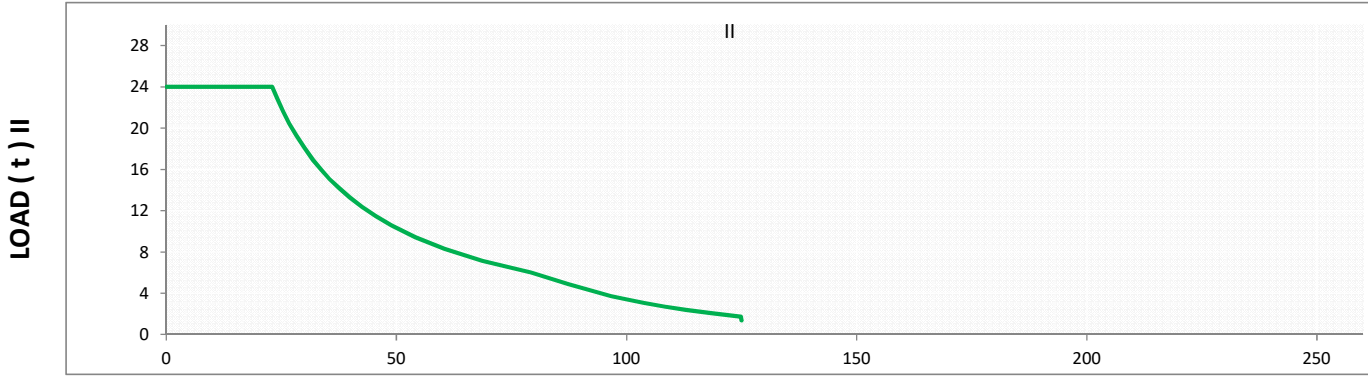
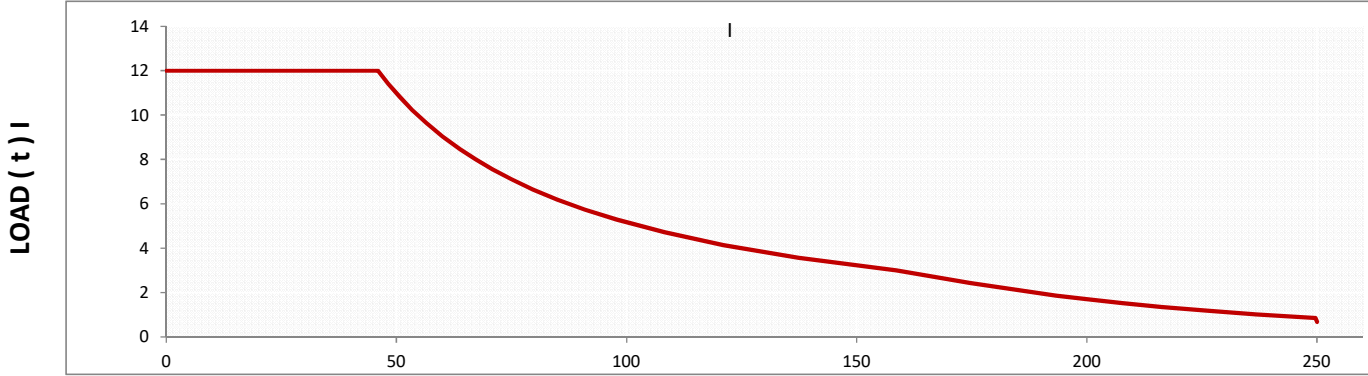

HOISTING

				t	m/min		kW			
	110 HVF 200			12	0	→	46	110	400	
				8	0	→	68			
				3	0	→	159			
				1,2	0	→	224			
				24	0	→	23			
				16	0	→	34			
				6	0	→	79			
				2,4	0	→	112			

	HOISTING WINCH	110	kW	Max Rope	400	m
	LUFFING WINCH	67	kW	Trolley speed	2,2	min
	SLEWING	2 x 11	kW		S+L+H	290 kVA



RTL 325 A-20 HR23/HP20



MORITSCH

CRANES SINCE 1962

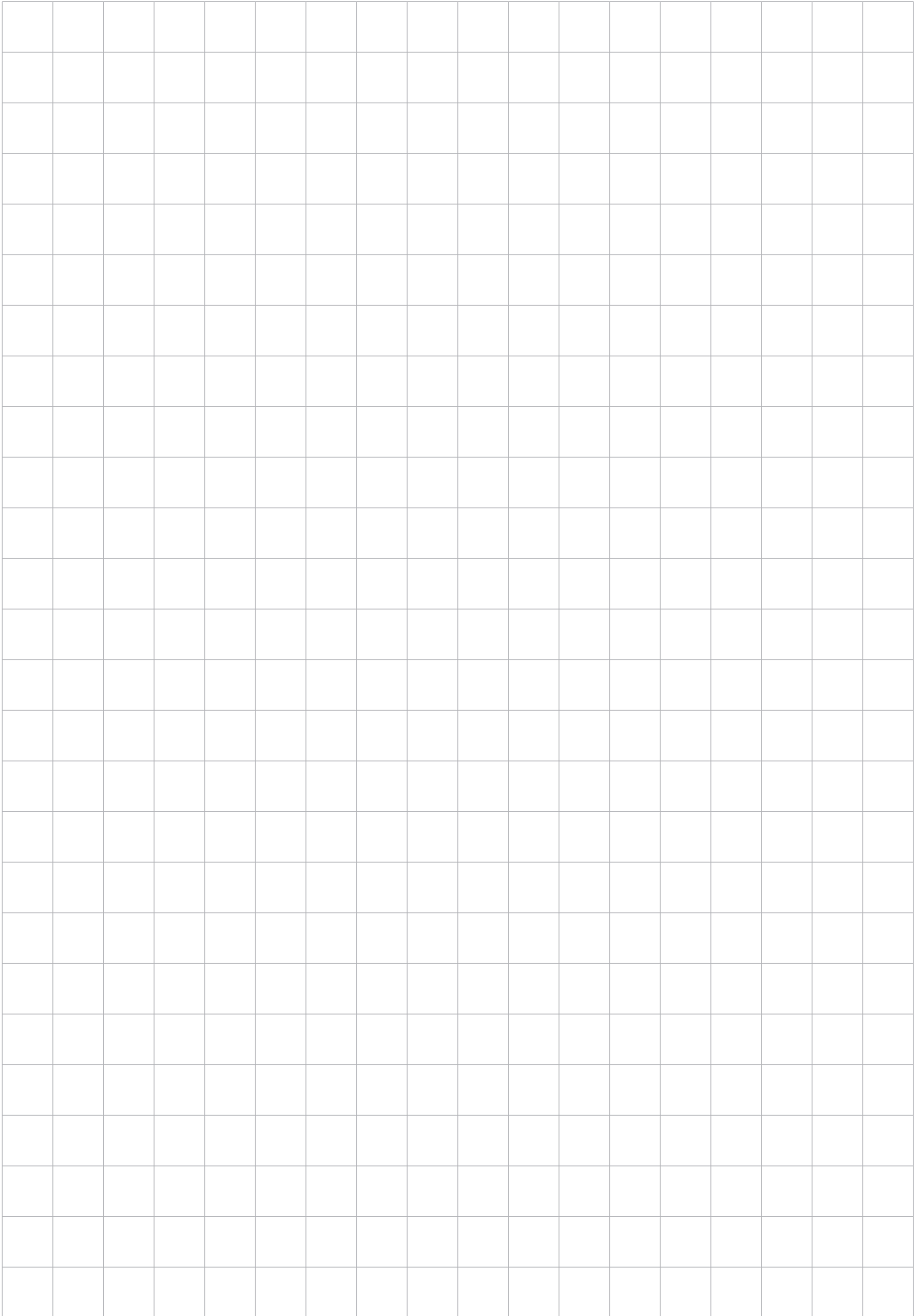

RTL 325 A-20 HR23/HP20



MORITSCH

CRANES SINCE 1962

Moritsch Cranes S.r.l.

via Ramentera 52
32035 Santa Giustina | BL | Italy

T. +39 0437 1840396

info@moritsch.it

www.moritsch.it

