

MANITOU MT-X 625 COMFORT



Model: MT-X 625 Comfort

Load Capacity: 2500KG

Max. Lifting Height: 5.85m

Height: 1.92m

Width: 1.82.

2 Speed Hydrostatic Transmission

Engine: Direct Injection Kubota 3307-T-E3B / 55,4 KW/75 HP / Max Torque 265Nm at 1400 rpm / Diesel

Engine Pre Cleaner fitted to assist with extreme dusty conditions

360 Degree Rotator fitted

Lockable Battery Isolator

Internal and External E-Stop

Boom Angle Indicator

Reverse Camera

This spec sheet is provided for information only and is subject to change.

DIMENSIONS AND LOAD CHARTS

A	mm	1200
B	mm	2300
C	mm	991
C1	mm	928
D	mm	3894
D1	mm	3831
D2	mm	3275
E	mm	5094
F	mm	1492
F1	mm	1492
G	mm	240
G1	mm	330
G2	mm	253
G3	mm	-
H	'	-
H1	'	-
I	mm	603
J	mm	797
K	mm	1015
L	mm	45
N	mm	1314
O	mm	125
P2	'	37
P3	'	52
R	mm	3150
S	mm	6651,5
T	mm	3935
U1	mm	1920
U2	mm	2054
V	mm	4700
V1	mm	765
V2	mm	3310,5
W	mm	1813
W1	mm	-
W2	mm	-
W3	mm	-
Y	'	12
Z	'	117

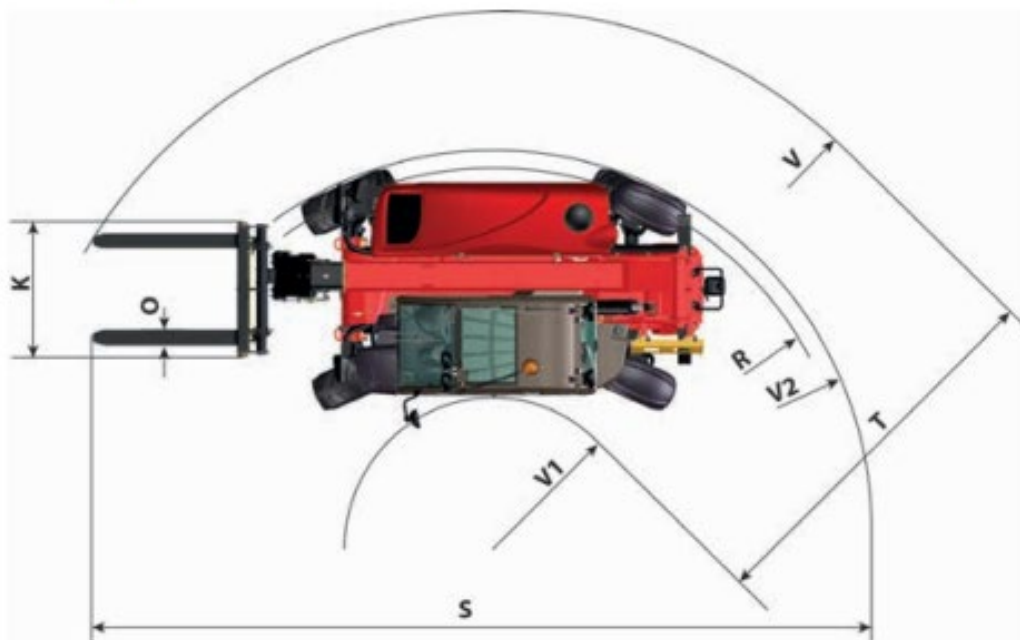
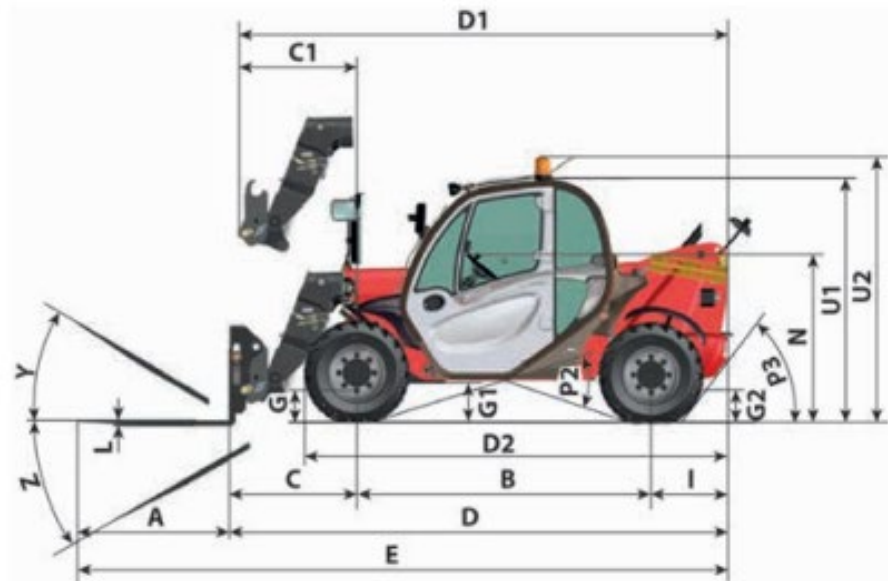

Under 2 m in height

1.92 m
1.82 m

to access low headroom and narrow entrances

Good ground clearance

0.33 m
3.90 m

to work on uneven ground conditions

Excellent turning radius

3.30 m

with **4 WHEEL STEERING** for easy manoeuvring
3 steering modes

2000 kg
5.85 m

Unload a lorry from just one side or place a 1.2 T pallet 2.50 m in front of the wheels, and up to 800 kg at 3.40 m.

1.2 T
2.50 m

YOU WANT A FORKLIFT TRUCK THAT IS EASY TO OPERATE

The ergonomic design of the MT625 is to meet your need for **SIMPLICITY**.

Why not try out its **10 second start-up**:

- Cabin access with no step
- Comfort seat
- Intuitive engine starting and handling JSM (Joystick Switch & Move®) joystick control

360° VISIBILITY
EASY STARTING
10s