

AUXILLARY

## LOADING BAY MKII



### Model – Workbox MKII

Our range of large loading bays are perfect for specific jobs requiring greater access with less crane movements. These loading bays will allow occupants larger access to work areas at height.

A perfect solution for various work tasks or any inspections needing to be carried out.

### Specifications

- Tare Mass 1050kg
- SWL with NO occupants 2000kg
- SWL with 4 occupants 750kg
- Hardwearing galvanised finish
- Certified lifting gear supplied

**Spec Sheet**  
**LOADING BAY MKII**

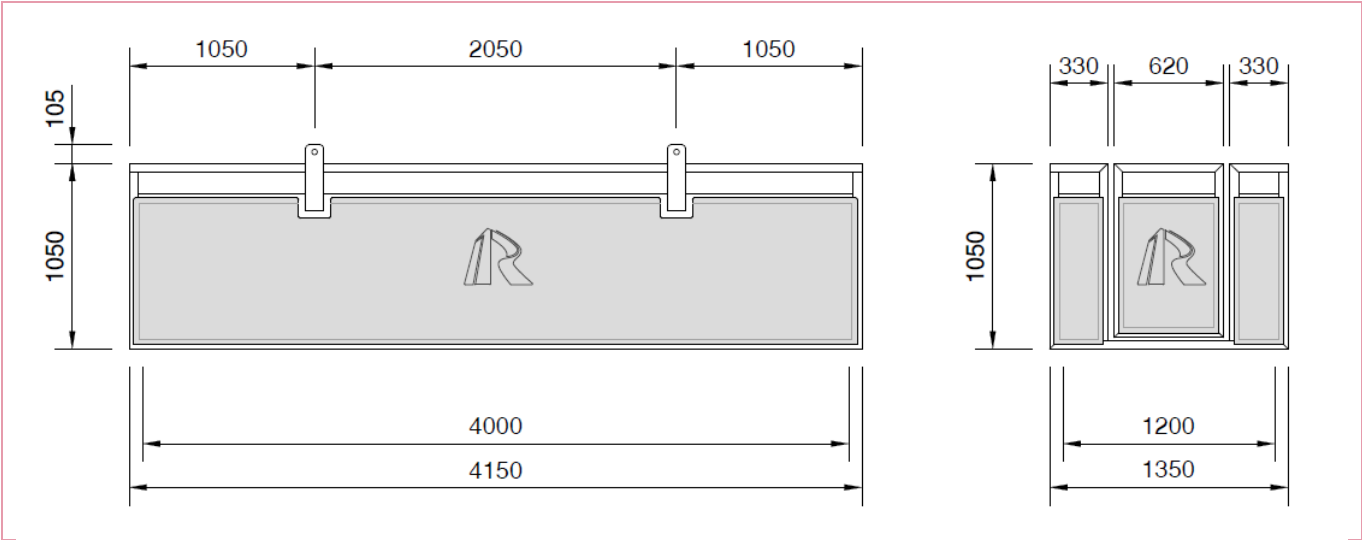

This spec sheet is provided for information only and is subject to change.

